



250 Staunton Turnpike, Parkersburg, WV 26104

7700/9900 Series Vinyl Horizontal Sliding Window "NON-IMPACT"

GENERAL NOTES

1. This product has been evaluated and is in compliance with the 8th Edition (2023) Florida Building Code (FBC) structural requirements excluding the "High Velocity Hurricane Zone" (HVHZ).
2. Product anchors shall be as listed and spaced as shown on details. Anchor embedment to base material shall be beyond wall dressing or stucco.
3. When used in areas requiring wind borne debris protection this product is required to be protected with an impact resistant covering that complies with FBC Sections 1609.1.2 & R301.2.1.2.
4. For 2x stud framing construction, anchoring of these units shall be the same as that shown for 2x buck masonry construction.
5. Site conditions that deviate from the details of this drawing require further engineering analysis by a licensed engineer or registered architect.

TABLE OF CONTENTS	
SHEET#	DESCRIPTION
1	Typical elevations, design pressures and general notes
2	Horizontal cross sections
3	Vertical cross sections
4	Buck and frame anchoring (Max. Frame Size: 96" x 72")
5	Buck and frame anchoring (Max. Frame Size: 72" x 48")
6	Bill of materials, components & glazing details

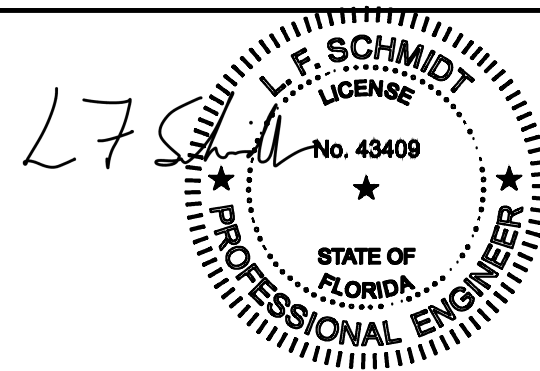

This item has been digitally signed and sealed by L. F. Schmidt, P.E. on the date adjacent to the seal. Printed copies of this document are not considered signed and sealed and the signature must be verified on any electronic copies.

THIS PRODUCT APPROVAL IS VALID ONLY FOR THE STATE OF FLORIDA

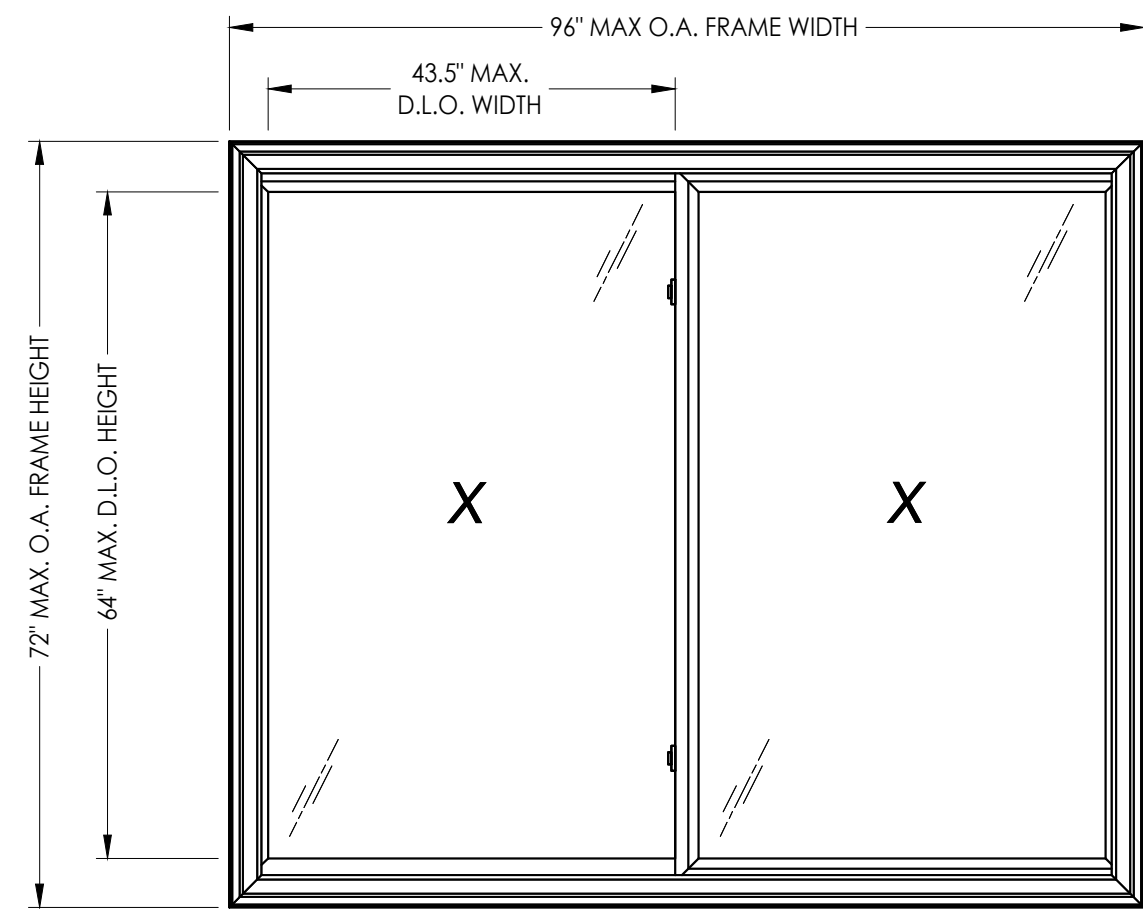

MAX. FRAME DIMENSION	MAX. D.L.O. DIMENSION	GLASS TYPE	DESIGN PRESSURE (PSF)	
			POSITIVE	NEGATIVE
96.0" X 72.0"	43.5" X 64.0"	G1	+15.0	-15.0
74.0" X 63.0"	32.5" X 55.0"	G1	+30.0	-30.0
84.0" X 54.0"	37.5" X 46.0"	G1	+35.0	-35.0
72.0" X 48.0"	31.5" X 40.0"	G1	+45.0	-45.0
63.0" X 44.0"	27.0" X 36.0"	G1	+50.0	-50.0

Documents Prepared By:
Lyndon F. Schmidt
P.E. No. 43409

7700/9900 SERIES

PART OR ASSEMBLY:
TYPICAL ELEVATION, DESIGN PRESSURES & GENERAL NOTES

NO.	DATE	REVISIONS
4	7/06/23	UPDATE TO 8TH ED. (2023) FBC LFS
3	7/06/20	UPDATE TO 7TH ED. (2020) FBC LFS
2	6/01/17	UPDATE TO 6TH ED. (2017) FBC LFS
1	1/28/15	UPDATE TO 5TH ED. (2014) FBC JK

DATE: 4/25/13

SCALE: N.T.S.

DWG. BY: JK

CHK. BY: LFS

DRAWING NO.: FL-16092.9

SHEET 1 OF 6

© 2013 R.W. BUILDING CONSULTANTS INC.

RW BUILDING CONSULTANTS, INC.
P.O. Box 230, Vairico, FL 33595
Phone No.: 813.659.9197
FBPE Registry No. 9813

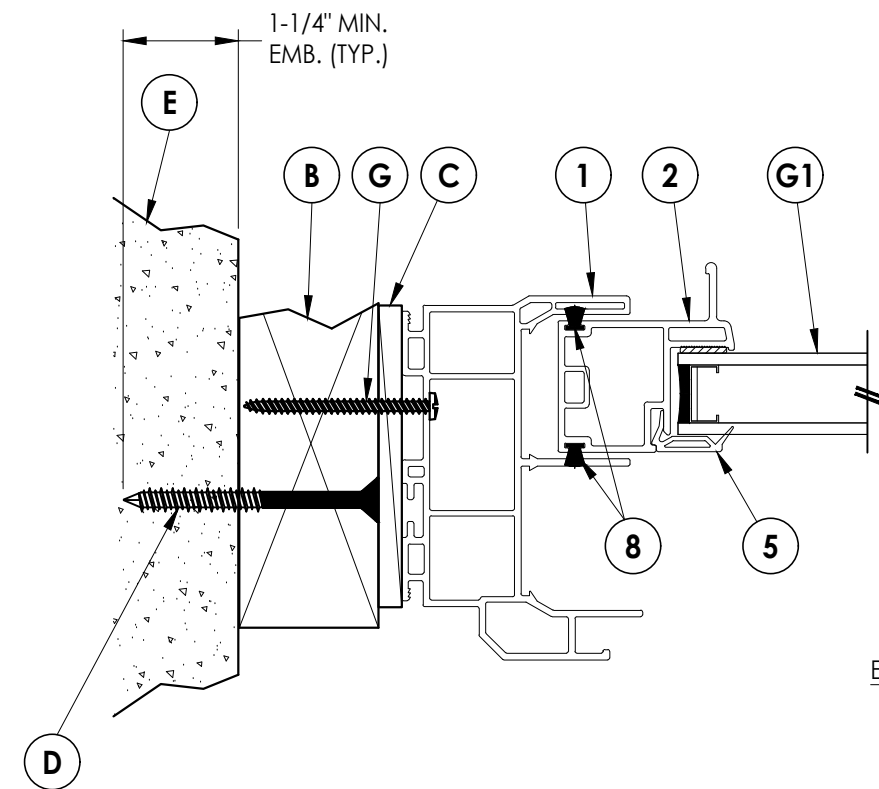
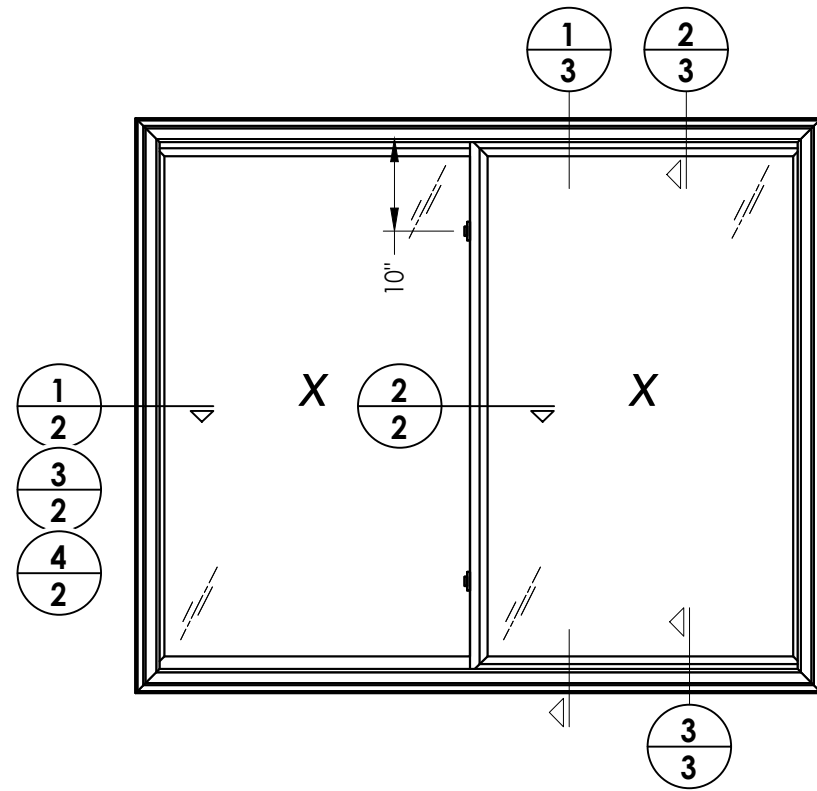

1 HORIZONTAL CROSS SECTION
2 Shown w/ 2X buck

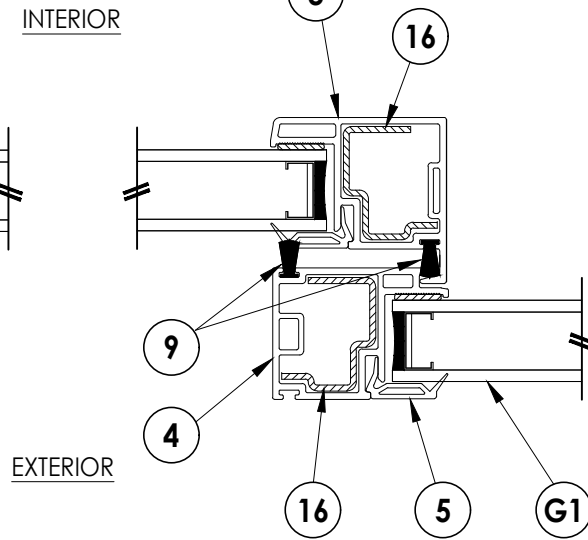

2 HORIZONTAL CROSS SECTION
2

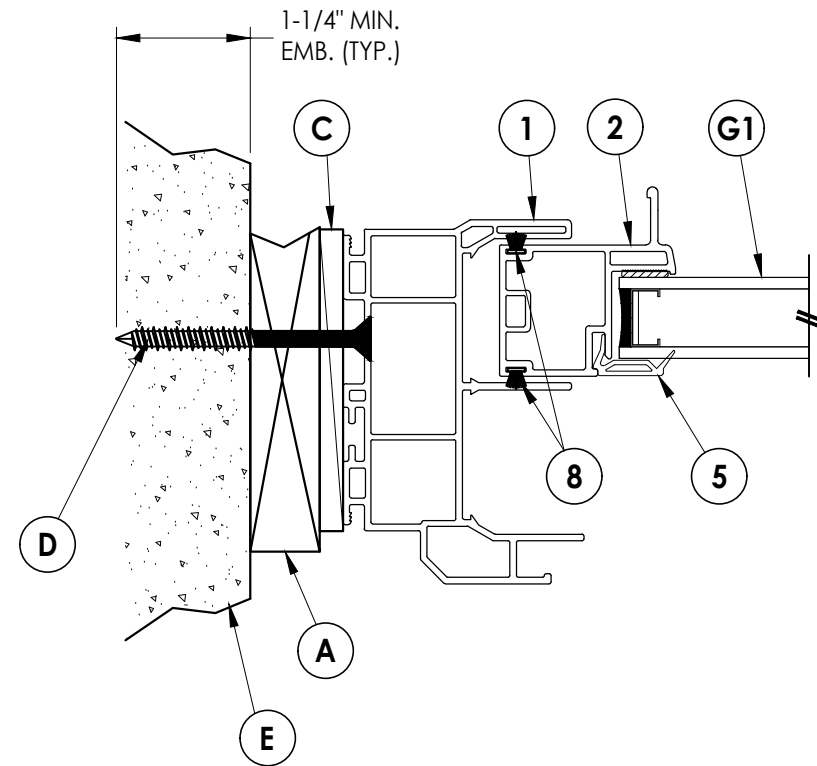

4 HORIZONTAL CROSS SECTION
2 Shown w/ 1X buck

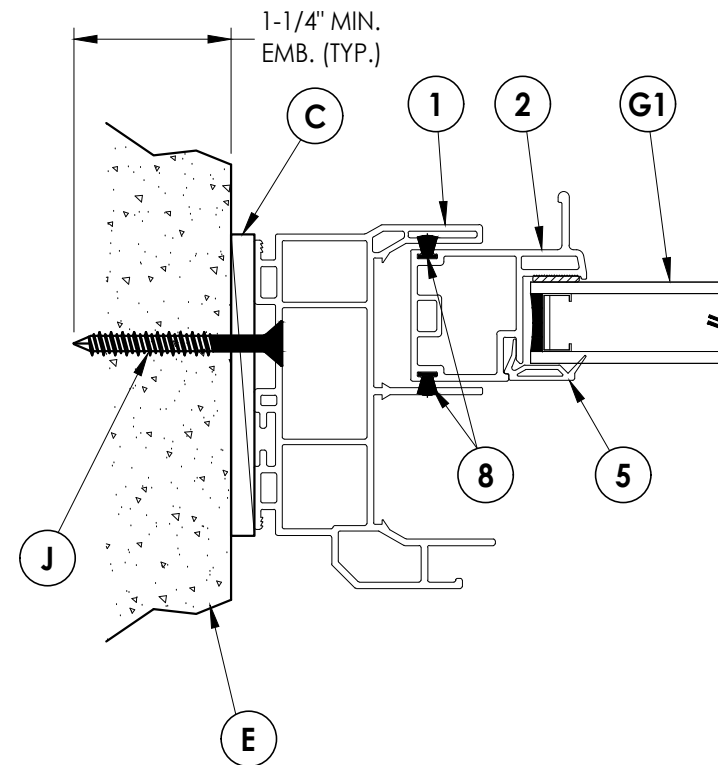

3 HORIZONTAL CROSS SECTION
2 Shown direct to masonry

Documents Prepared By:
 Lyndon F. Schmidt
 P.E. No. 43409

RW BUILDING CONSULTANTS, INC.
 P.O. Box 230, Valrico, FL 33595
 Phone No.: 813.659.9197
 FBPE Registry No. 9813

PRODUCT: 7700/9900 SERIES

PART OR ASSEMBLY:
 HORIZONTAL
 CROSS SECTIONS

NO.	DATE	REVISIONS
4	7/06/23	UPDATE TO 8TH ED. (2023) FBC LFS
3	7/06/20	UPDATE TO 7TH ED. (2020) FBC LFS
2	6/01/17	UPDATE TO 6TH ED. (2017) FBC LFS
1	1/28/15	UPDATE TO 5TH ED. (2014) FBC JK

DATE: 4/25/13

SCALE: N.T.S.

DWG. BY: JK

CHK. BY: LFS

DRAWING NO.:

FL-16092.9

SHEET 2 of 6

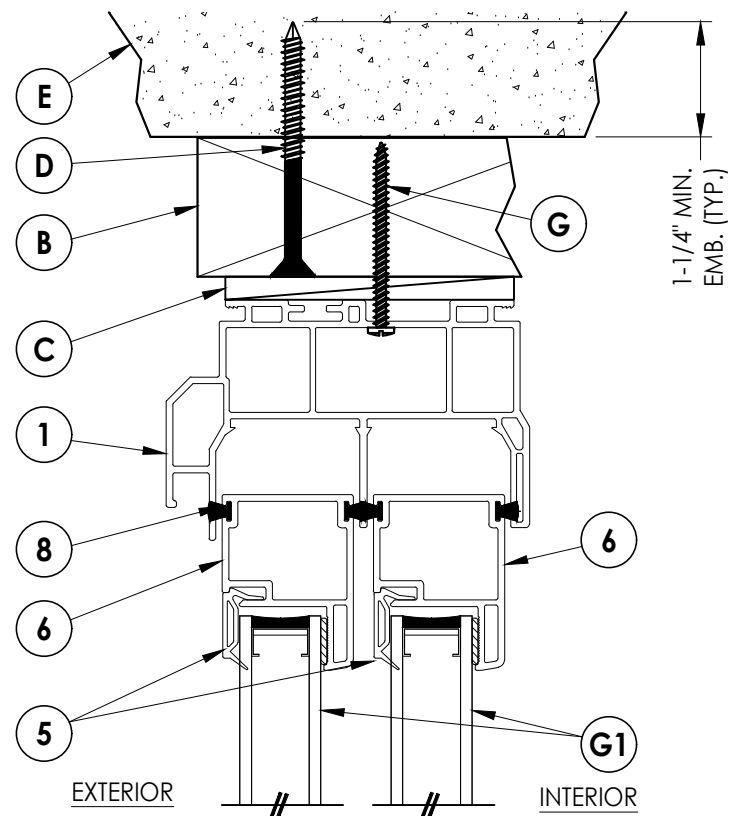

1 VERTICAL CROSS SECTION
3 Shown w/ 2X buck

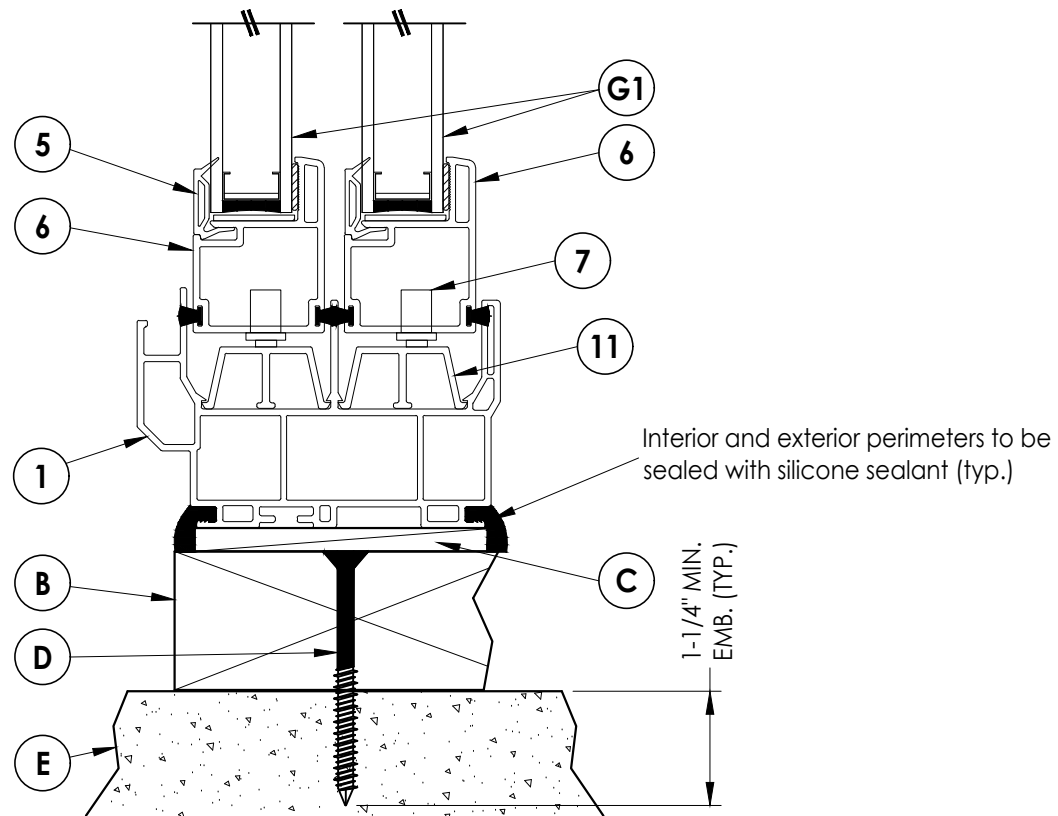

Interior and exterior perimeters to be sealed with silicone sealant (typ.)

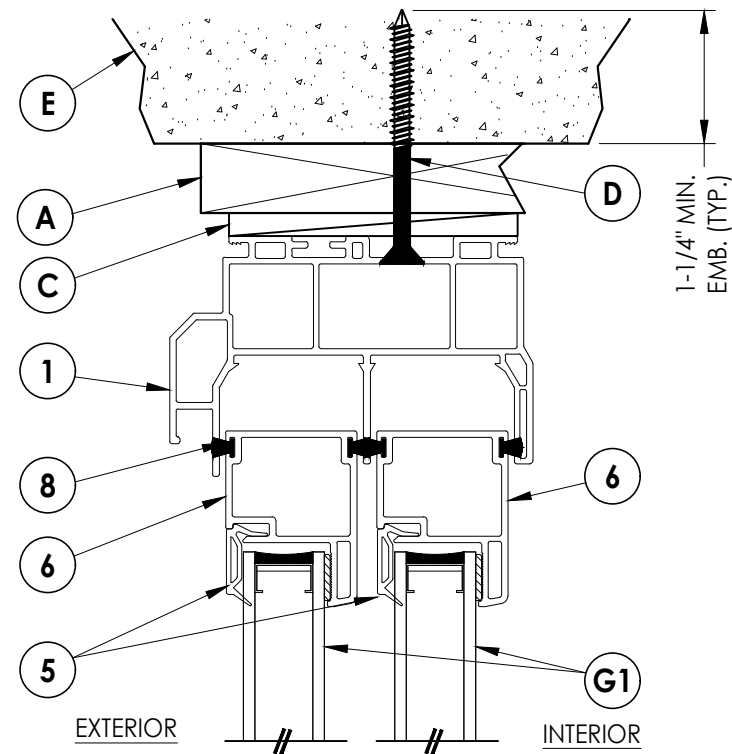

2 VERTICAL CROSS SECTION
3 Shown w/ 1X buck

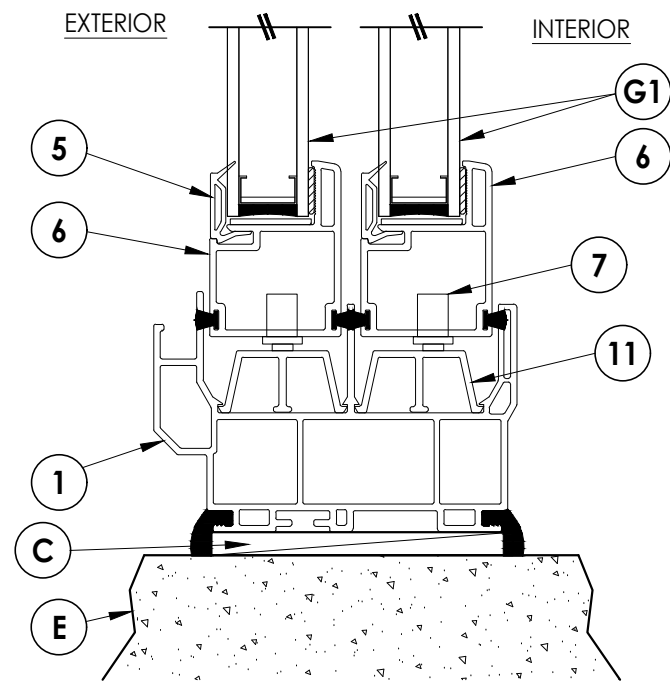

3 VERTICAL CROSS SECTION
3 Shown direct to masonry

Documents Prepared By:
 Lyndon F. Schmidt
 P.E. No. 43409

RW BUILDING CONSULTANTS, INC.
 P.O. Box 230, Valrico, FL 33595
 Phone No.: 813.659.9197
 FBPE Registry No. 9813

PRODUCT: 7700/9900 SERIES

PART OR ASSEMBLY:
 VERTICAL
 CROSS SECTIONS

NO.	DATE	REVISIONS	BY
4	7/06/23	UPDATE TO 8TH ED. (2023)	FBC LFS
3	7/06/20	UPDATE TO 7TH ED. (2020)	FBC LFS
2	6/01/17	UPDATE TO 6TH ED. (2017)	FBC JK
1	1/28/15	UPDATE TO 5TH ED. (2014)	FBC JK

DATE: 4/25/13

SCALE: N.T.S.

DWG. BY: JK

CHK. BY: LFS

DRAWING NO.:

FL-16092.9

SHEET 3 OF 6

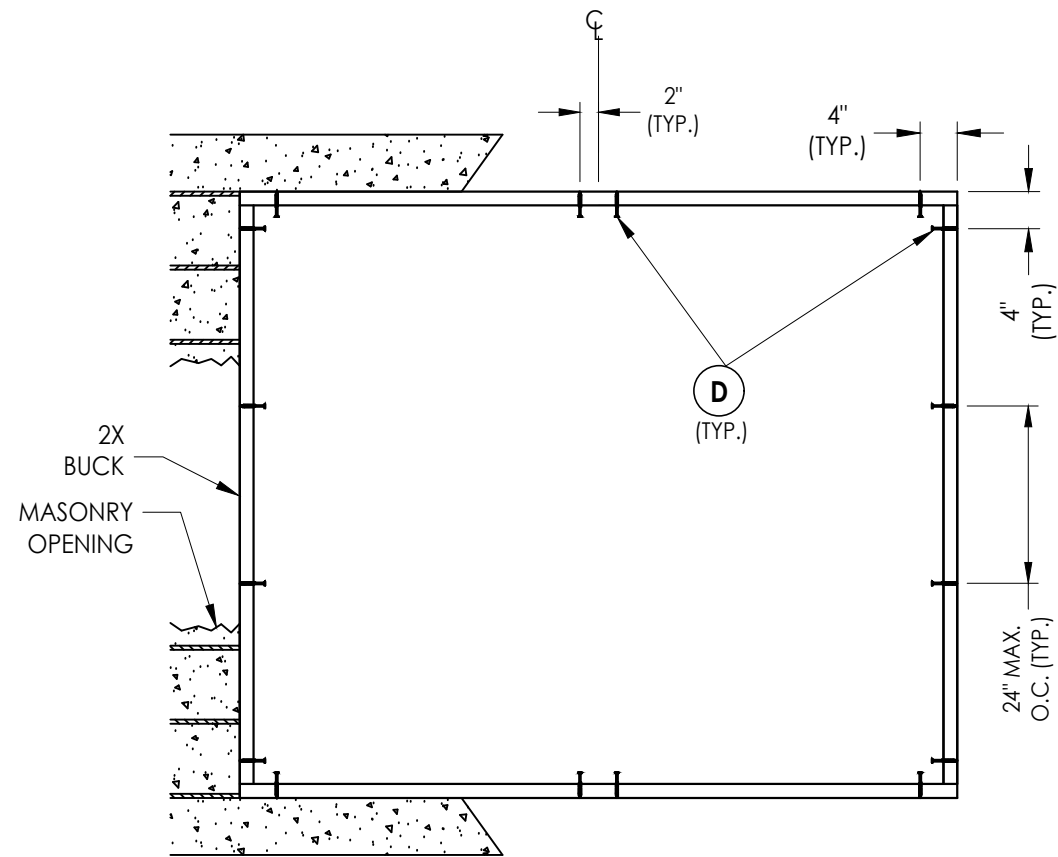

BUCK ANCHORING

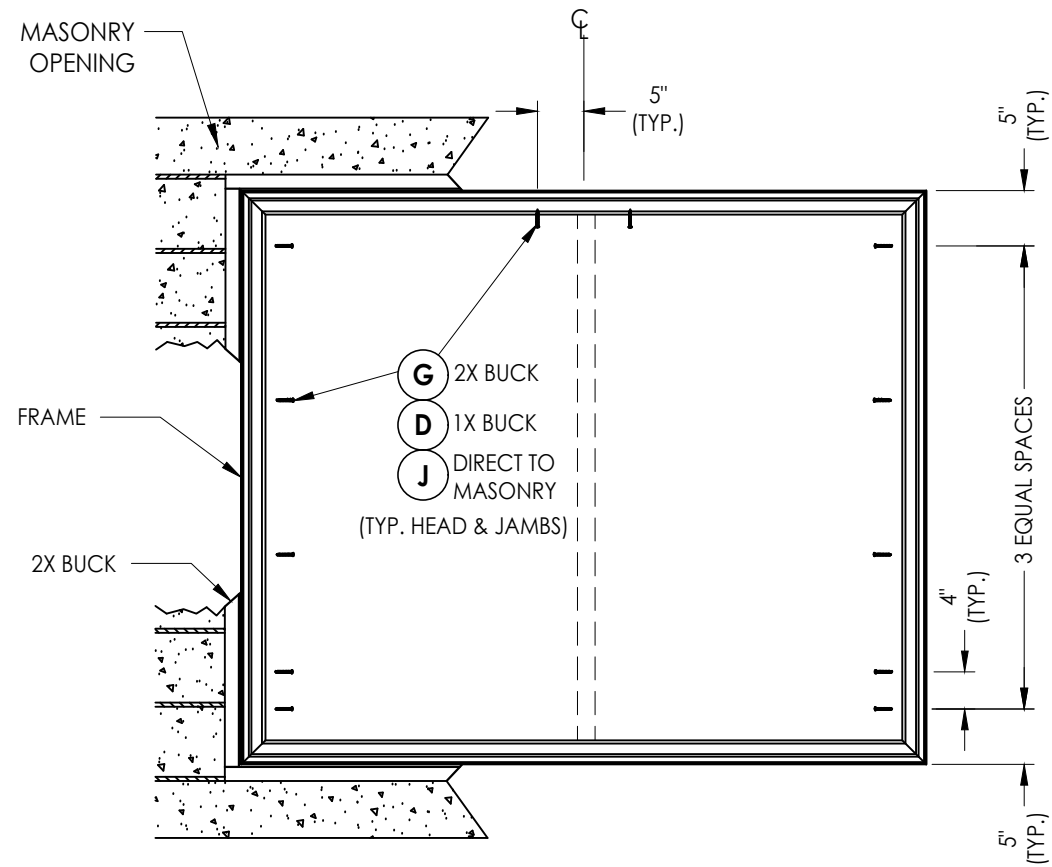

FRAME ANCHORING

MAX. FRAME SIZE: 96" X 72"

CONCRETE ANCHOR NOTES:

1. Concrete anchor locations at the corners may be adjusted to maintain the min. edge distance to mortar joints.
2. Concrete anchor locations noted as "MAX. ON CENTER" must be adjusted to maintain the min. edge distance to mortar joints, additional concrete anchors may be required to ensure the "MAX. ON CENTER" dimension are not exceeded.
3. Concrete anchor table:

ANCHOR TYPE	ANCHOR SIZE	MIN. EMBEDMENT	MIN. CLEARANCE TO MASONRY EDGE	MIN. CLEARANCE TO ADJACENT ANCHOR
ITW TAPCON®	1/4"	1-1/4"	2"	4"
DeWALT ULTRACON®	1/4"	1-1/4"	1"	4"

WOOD SCREW INSTALLATION NOTES:

1. Maintain a minimum 5/8" edge distance, 1" end distance, & 1" o.c. spacing of wood screws to prevent the splitting of wood.

Documents Prepared By:
Lyndon F. Schmidt
P.E. No. 43409

RW BUILDING CONSULTANTS, INC.
P.O. Box 230, Vairico, FL 33595
Phone No.: 813.659.9197
FBPE Registry No. 9813

PRODUCT: 7700/9900 SERIES

PART OR ASSEMBLY:
BUCK AND FRAME ANCHORING
(MAX FRAME SIZE: 96" x 72")

NO.	DATE	REVISIONS
4	7/06/23	UPDATE TO 8TH ED. (2023) FBC LFS
3	7/06/20	UPDATE TO 7TH ED. (2020) FBC LFS
2	6/01/17	UPDATE TO 6TH ED. (2017) FBC LFS
1	1/28/15	UPDATE TO 5TH ED. (2014) FBC JK
		BY

DATE: 4/25/13

SCALE: N.T.S.

DWG. BY: JK

CHK. BY: LFS

DRAWING NO.:

FL-16092.9

SHEET 4 OF 6

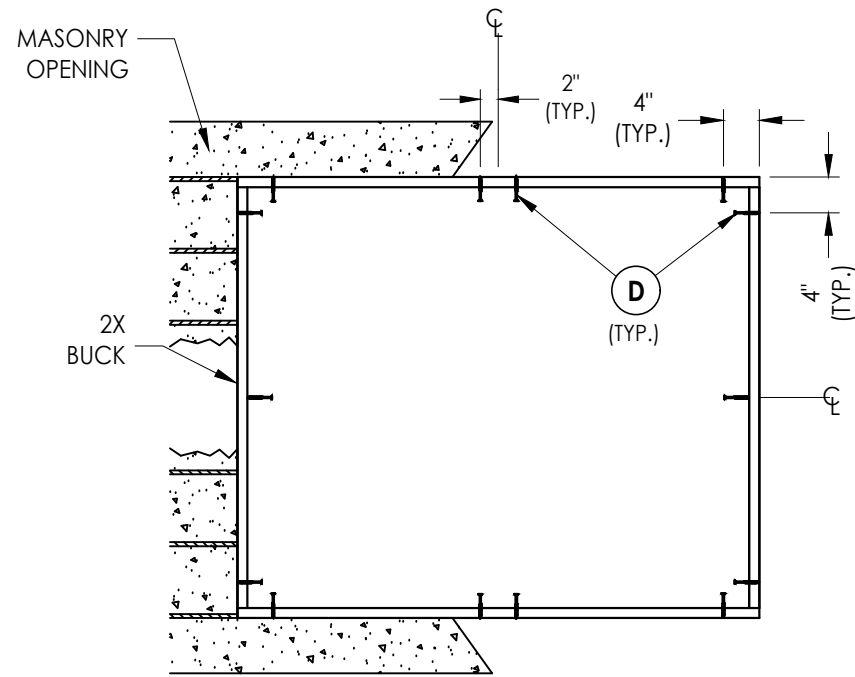

BUCK ANCHORING

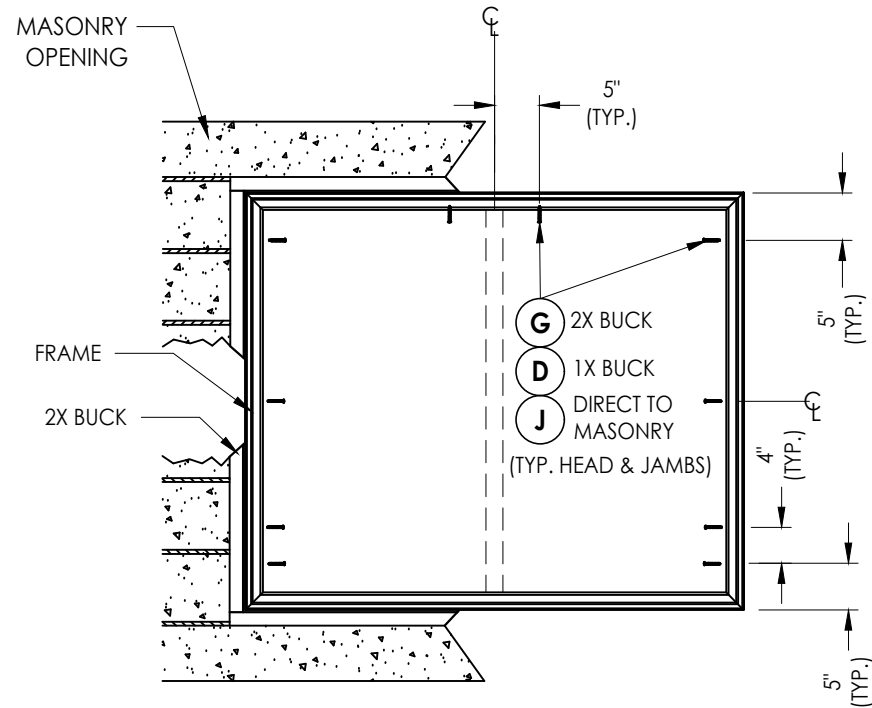

FRAME ANCHORING

MAX. FRAME SIZE: 72" X 48"

CONCRETE ANCHOR NOTES:

1. Concrete anchor locations at the corners may be adjusted to maintain the min. edge distance to mortar joints.
2. Concrete anchor locations noted as "MAX. ON CENTER" must be adjusted to maintain the min. edge distance to mortar joints, additional concrete anchors may be required to ensure the "MAX. ON CENTER" dimension are not exceeded.
3. Concrete anchor table:

ANCHOR TYPE	ANCHOR SIZE	MIN. EMBEDMENT	MIN. CLEARANCE TO MASONRY EDGE	MIN. CLEARANCE TO ADJACENT ANCHOR
ITW TAPCON®	1/4"	1-1/4"	2"	4"
DeWALT ULTRACON®	1/4"	1-1/4"	1"	4"

WOOD SCREW INSTALLATION NOTES:

1. Maintain a minimum 5/8" edge distance, 1" end distance, & 1" o.c. spacing of wood screws to prevent the splitting of wood.

Documents Prepared By:
Lyndon F. Schmidt
P.E. No. 43409

RW
BUILDING CONSULTANTS, INC.
P.O. Box 230, Valrico, FL 33595
Phone No.: 813.659.9197
FBPE Registry No. 9813

PRODUCT: 7700/9900 SERIES

PART OR ASSEMBLY:
BUCK AND FRAME ANCHORING
(MAX FRAME SIZE: 72" x 48")

NO.	DATE	REVISIONS
4	7/06/23	UPDATE TO 8TH ED. (2023) FBC LFS
3	7/06/20	UPDATE TO 7TH ED. (2020) FBC LFS
2	6/01/17	UPDATE TO 6TH ED. (2017) FBC LFS
1	1/28/15	UPDATE TO 5TH ED. (2014) FBC JK
		BY

DATE: 4/25/13

SCALE: N.T.S.

DWG. BY: JK

CHK. BY: LFS

DRAWING NO.:

FL-16092.9

SHEET 5 OF 6

BILL OF MATERIALS		
ITEM #	DESCRIPTION	MATERIAL
A	1X BUCK (SG >= 0.42)	WOOD
B	2X BUCK (SG >= 0.42)	WOOD
C	1/4" MAX. SHIM SPACE	-
D	1/4" X 2-3/4" PFH DeWALT OR ITW CONCRETE SCREW	STEEL
E	MASONRY - 3,000 PSI MIN. CONCRETE CONFORMING TO ACI 301 OR HOLLOW BLOCK CONFORMING TO ASTM C90	CONCRETE
G	#8 X 2" PPH WOOD SCREW (1-7/16" MIN. EMBEDMENT)	STEEL
J	1/4" X 2-1/4" PFH DeWALT OR ITW CONCRETE SCREW	STEEL
1	FRAME*	PVC
2	SLIDER PULL STILE*	PVC
3	LOCK STILE*	PVC
4	KEEPER STILE*	PVC
5	GLAZING BEAD*	PVC
6	SLIDER COMMON RAIL*	PVC
7	METAL ROLLERS w/ PLASTIC HOUSING	-
8	WEATHERSTRIP (0.230")	-
9	WEATHERSTRIP (0.380")	-
11	SILL TRACK	ALUM
16	REINFORCEMENT (LOCK & MEETING STILE) (CS TYPE B HOT DIPPED GALV.)	STEEL

* THE APPROVED WHITE RIGID PVC EXTERIOR EXTRUSIONS FOR WINDOWS ARE TO BE PRODUCED BY EXTRUDERS LICENSEES IN "AAMA CERTIFICATION PROGRAMS FOR RIGID PVC EXTRUSIONS".

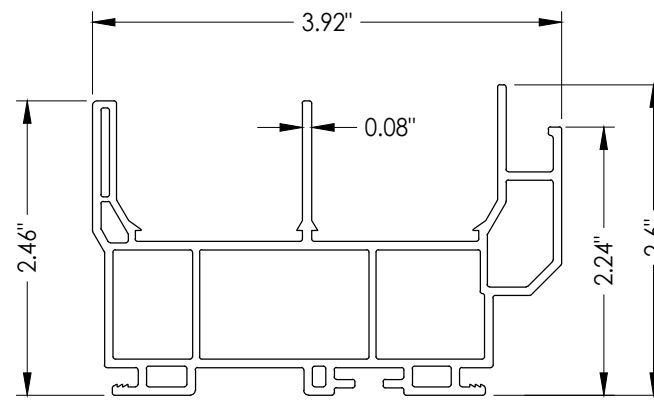

1 FRAME

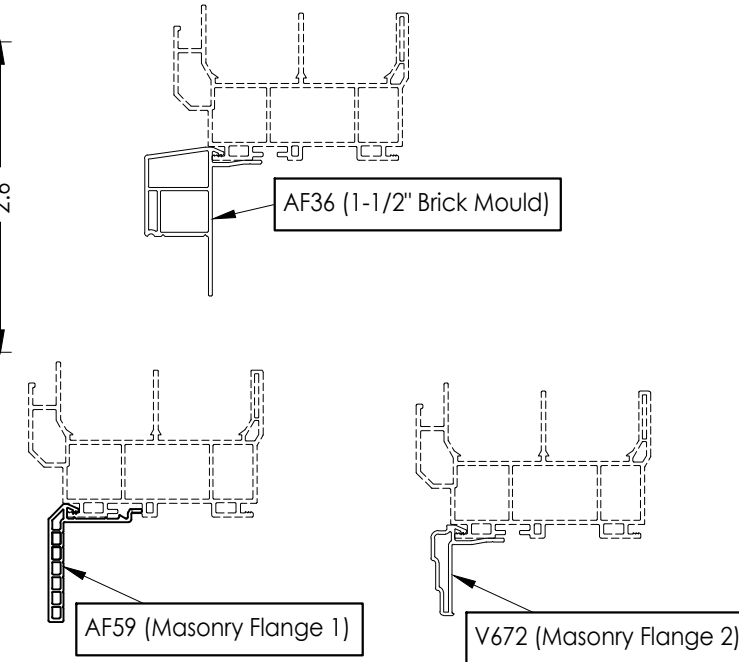

OPTIONAL COSMETIC FLANGES

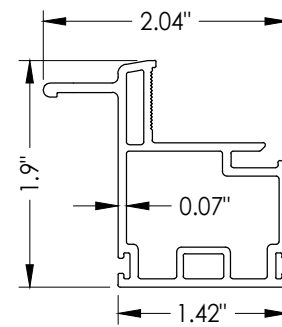

2 SLIDER PULL STILE

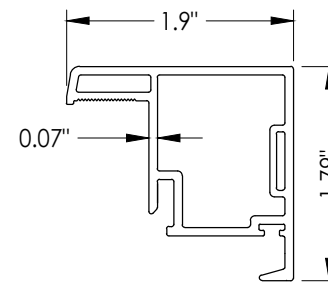

3 LOCK STILE

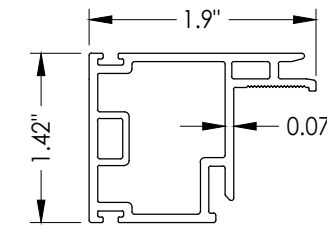

4 KEEPER STILE

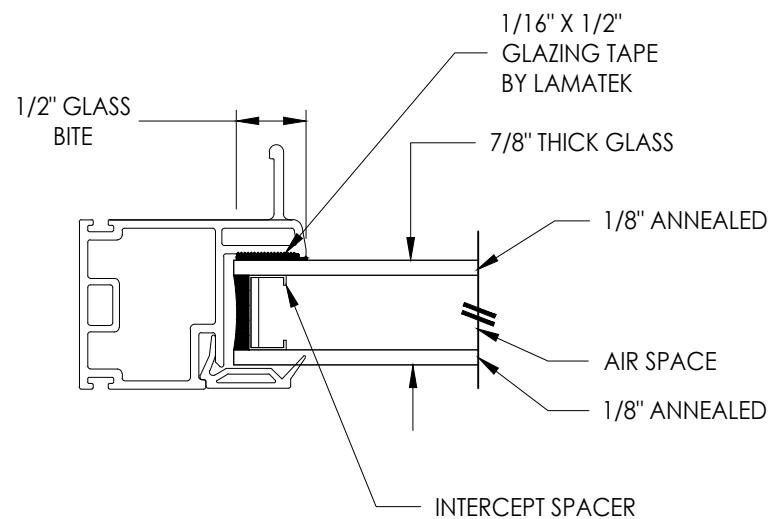

G1 GLAZING DETAIL

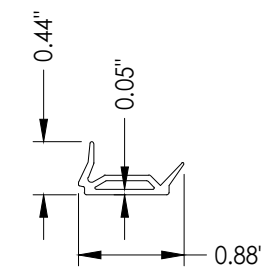

5 GLAZING BEAD

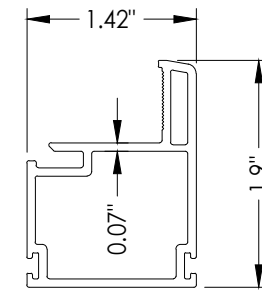

6 SLIDER COMMON RAIL

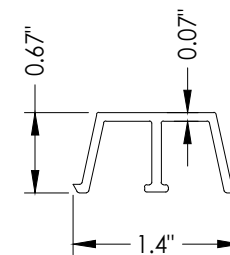

11 SILL TRACK

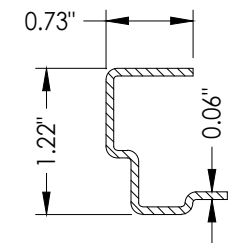

16 REINFORCEMENT
Lock & Meeting Stile

Documents Prepared By:
Lyndon F. Schmidt
P.E. No. 43409

RW
BUILDING CONSULTANTS, INC.
P.O. Box 230, Valrico, FL 33595
Phone No.: 813.659.9197
FBPE Registry No. 9813

PRODUCT: 7700/9900 SERIES

PART OR ASSEMBLY:
BILL OF MATERIALS, COMPONENTS
& GLAZING DETAILS

NO.	DATE	REVISIONS
4	7/06/23	UPDATE TO 8TH ED. (2023) FBC LFS
3	7/06/20	UPDATE TO 7TH ED. (2020) FBC LFS
2	6/01/17	UPDATE TO 6TH ED. (2017) FBC LFS
1	1/28/15	UPDATE TO 5TH ED. (2014) FBC JK

DATE: 4/25/13

SCALE: N.T.S.

DWG. BY: JK

CHK. BY: LFS

DRAWING NO.: FL-16092.9

SHEET 6 OF 6